

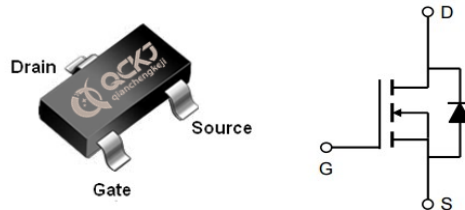
**Features SOT23**

- Low  $R_{DS(on)}$  @  $V_{GS}=4.5V$
- 3.3V Logic Level Control
- N Channel SOT23 Package
- Pb-Free, RoHS Compliant

$V_{(BR)DSS}$	$R_{DS(ON)}$ Typ	$I_D$ Max
20V	28m $\Omega$ @ 4.5V	3.6A
	32m $\Omega$ @ 3.3V	

**Applications**

- Load Switch
- DC/DC Converter
- Switching Circuits
- LED Driver



**Order Information**

Product	Package	Marking	Packing	Min Unit Quantity
QC2302	SOT23		3000PCS/Reel	3000PCS

**Absolute Maximum Ratings**

Stresses exceeding Maximum Ratings may damage the device. Maximum Ratings are stress ratings only. Functional operation above the Recommended Operating Conditions is not implied. Extended exposure to stresses above the Recommended Operating Conditions may affect device reliability.

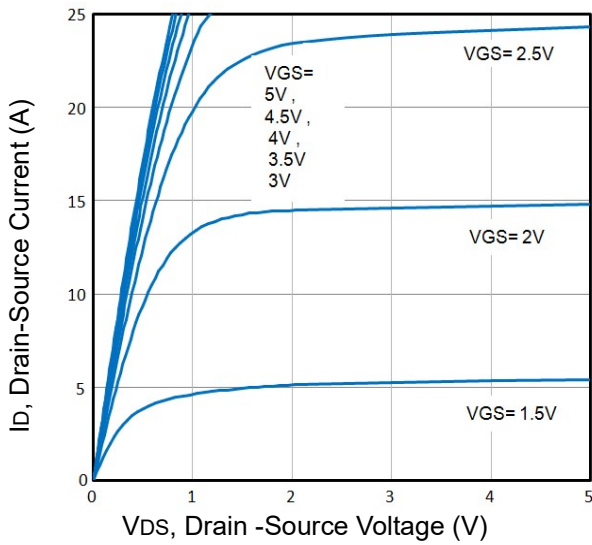
Symbol	Parameter	Rating	Unit	
<b>Common Ratings (TA=25°C Unless Otherwise Noted)</b>				
$V_{GS}$	Gate-Source Voltage	±10	V	
$V_{(BR)DSS}$	Drain-Source Breakdown Voltage	20	V	
$T_J$	Maximum Junction Temperature	150	°C	
$T_{STG}$	Storage Temperature Range	-50 to 150	°C	
<b>Mounted on Large Heat Sink</b>				
$I_{DM}$	Pulse Drain Current Tested①	$T_A=25^\circ C$	18	A
$I_D$	Continuous Drain Current( $V_{GS}=4.5V$ )	$T_A=25^\circ C$	3.6	A
		$T_A=70^\circ C$	3.0	
$P_D$	Maximum Power Dissipation	$T_A=25^\circ C$	1.2	W
		$T_A=70^\circ C$	0.9	
$R_{\theta JA}$	Thermal Resistance Junction-Ambient	100	°C/W	

Symbol	Parameter	Condition	Min	Typ	Max	Unit
<b>Static Electrical Characteristics @ T<sub>J</sub> = 25°C (unless otherwise stated)</b>						
V <sub>(BR)DSS</sub>	Drain-Source Breakdown Voltage	V <sub>GS</sub> =0V I <sub>D</sub> =250μA	20	--	--	V
I <sub>DSS</sub>	Zero Gate Voltage Drain Current(T <sub>A</sub> =25°C)	V <sub>DS</sub> =20V, V <sub>GS</sub> =0V	--	--	1	μA
	Zero Gate Voltage Drain Current(T <sub>A</sub> =125°C)	V <sub>DS</sub> =16V, V <sub>GS</sub> =0V	--	--	100	uA
I <sub>GSS</sub>	Gate-Body Leakage Current	V <sub>GS</sub> =±10V, V <sub>DS</sub> =0V	--	--	±100	nA
V <sub>GS(TH)</sub>	Gate Threshold Voltage	V <sub>DS</sub> =V <sub>GS</sub> , I <sub>D</sub> =250μA	0.4	0.6	1.0	V
R <sub>DS(ON)</sub>	Drain-Source On-State Resistance②	V <sub>GS</sub> =4.5V, I <sub>D</sub> =4A	--	28	35	mΩ
R <sub>DS(ON)</sub>	Drain-Source On-State Resistance②	V <sub>GS</sub> =3.3V, I <sub>D</sub> =2A	--	32	40	mΩ
R <sub>DS(ON)</sub>	Drain-Source On-State Resistance②	V <sub>GS</sub> =2.5V, I <sub>D</sub> =1A	--	36	45	mΩ
<b>Dynamic Electrical Characteristics @ T<sub>J</sub> = 25°C (unless otherwise stated)</b>						
C <sub>iss</sub>	Input Capacitance	V <sub>DS</sub> =10V, V <sub>GS</sub> =0V, f=1MHz	--	280	--	pF
C <sub>oss</sub>	Output Capacitance		--	46	--	pF
C <sub>rss</sub>	Reverse Transfer Capacitance		--	42	--	pF
Q <sub>g</sub>	Total Gate Charge	V <sub>DS</sub> =10V I <sub>D</sub> =3A, V <sub>GS</sub> =5V	--	4.7	--	nC
Q <sub>gs</sub>	Gate Source Charge		--	0.6	--	nC
Q <sub>gd</sub>	Gate Drain Charge		--	1.7	--	nC
<b>Switching Characteristics</b>						
t <sub>d(on)</sub>	Turn on Delay Time	V <sub>DD</sub> =10V, I <sub>D</sub> =4A, R <sub>G</sub> =3.3Ω, V <sub>GS</sub> =4.5V	--	11	--	ns
t <sub>r</sub>	Turn on Rise Time		--	35	--	ns
t <sub>d(off)</sub>	Turn Off Delay Time		-	25	--	ns
t <sub>f</sub>	Turn Off Fall Time		--	32	--	ns
<b>Source Drain Diode Characteristics</b>						
I <sub>SD</sub>	Source drain current(Body Diode)	T <sub>A</sub> =25°C	--	--	1.8	A
V <sub>SD</sub>	Forward on voltage②	T <sub>J</sub> =25°C, I <sub>SD</sub> =2A, V <sub>GS</sub> =0V	--	0.74	1.2	V

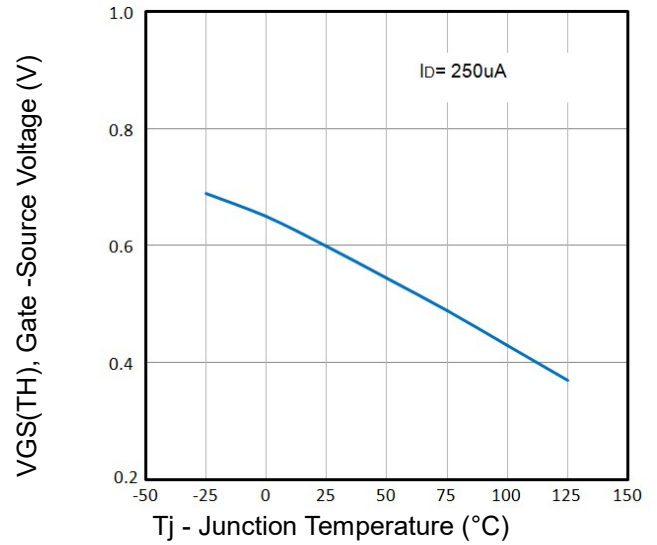
Notes:

- ⊙ Pulse width limited by maximum allowable junction temperature
- ⊙ Pulse test ; Pulse width≤300μs, duty cycle≤2%.

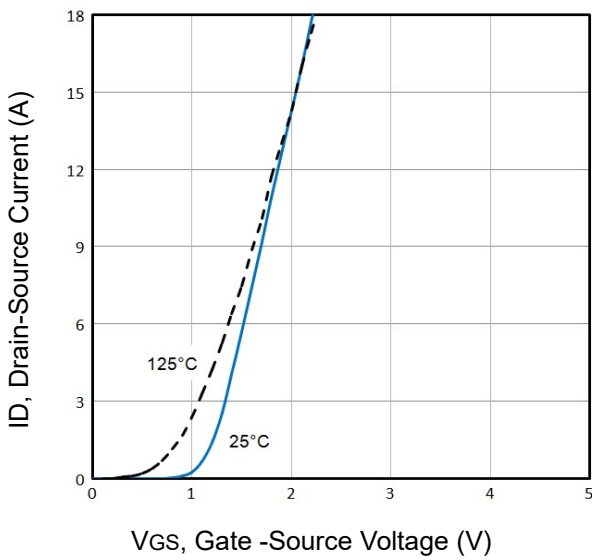
**Typical Characteristics**



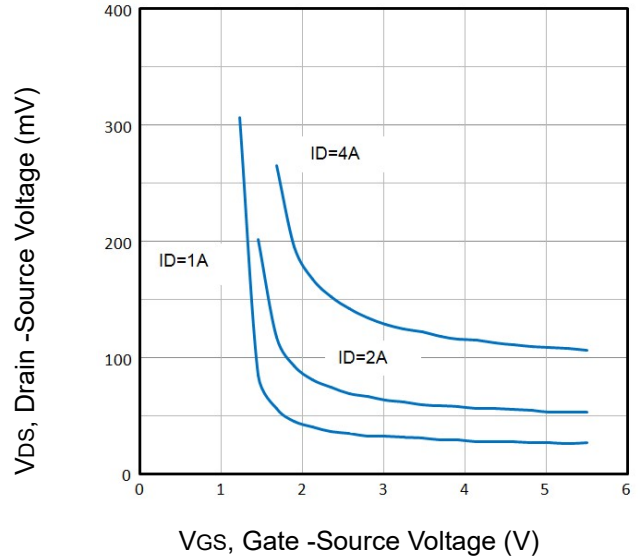
**Fig1.** Typical Output Characteristics



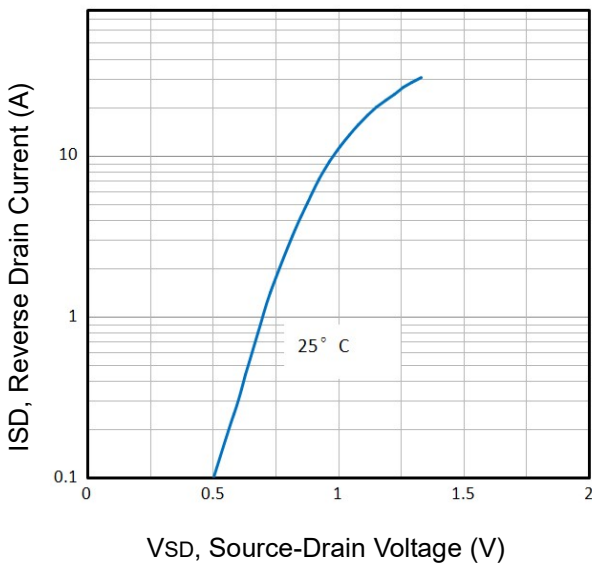
**Fig2.** Normalized Threshold Voltage Vs. Temperature



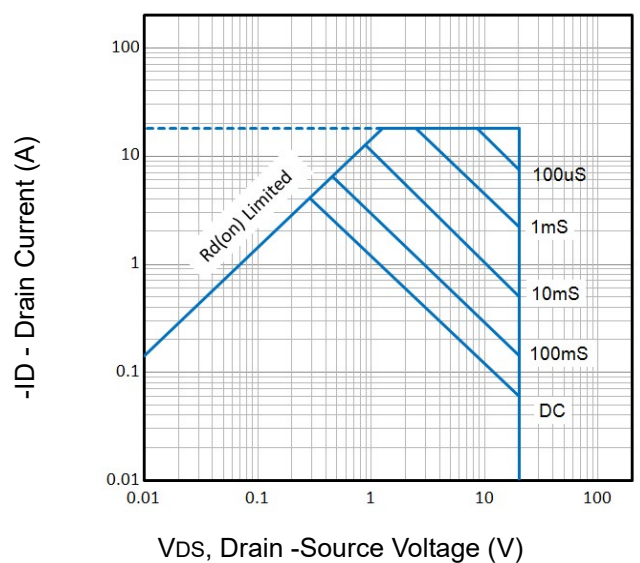
**Fig3.** Typical Transfer Characteristics



**Fig4.** Drain-Source Voltage vs Gate-Source Voltage

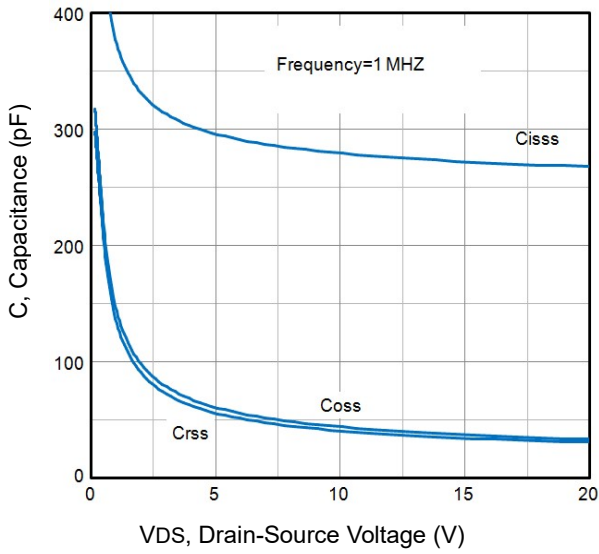


**Fig5.** Typical Source-Drain Diode Forward Voltage

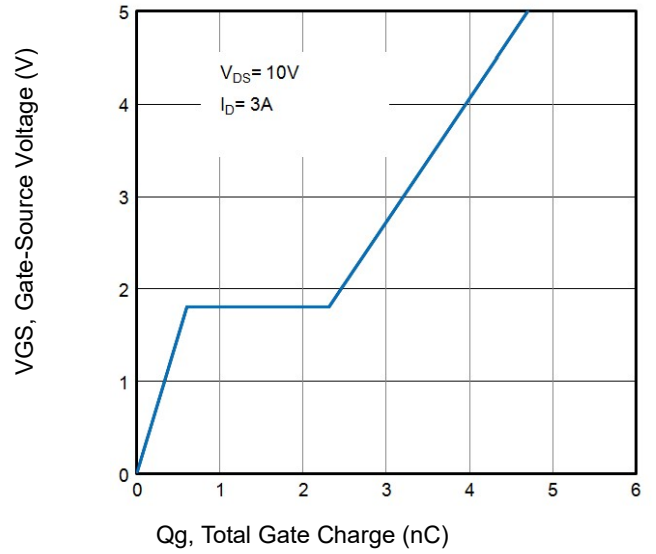


**Fig6.** Maximum Safe Operating Area

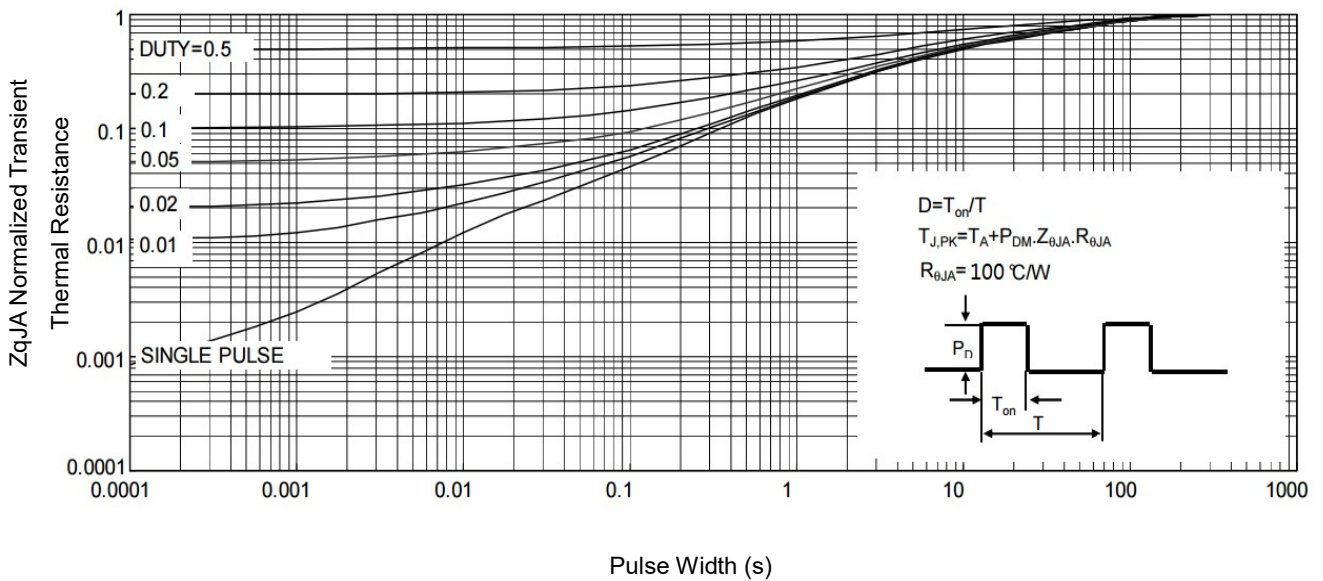
**Typical Characteristics**



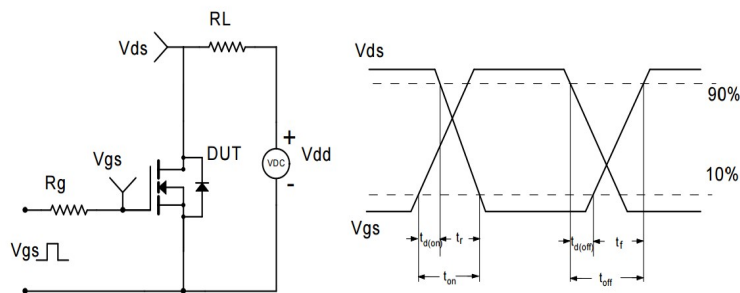
**Fig7.** Typical Capacitance Vs. Drain-Source Voltage



**Fig8.** Typical Gate Charge Vs. Gate-Source Voltage

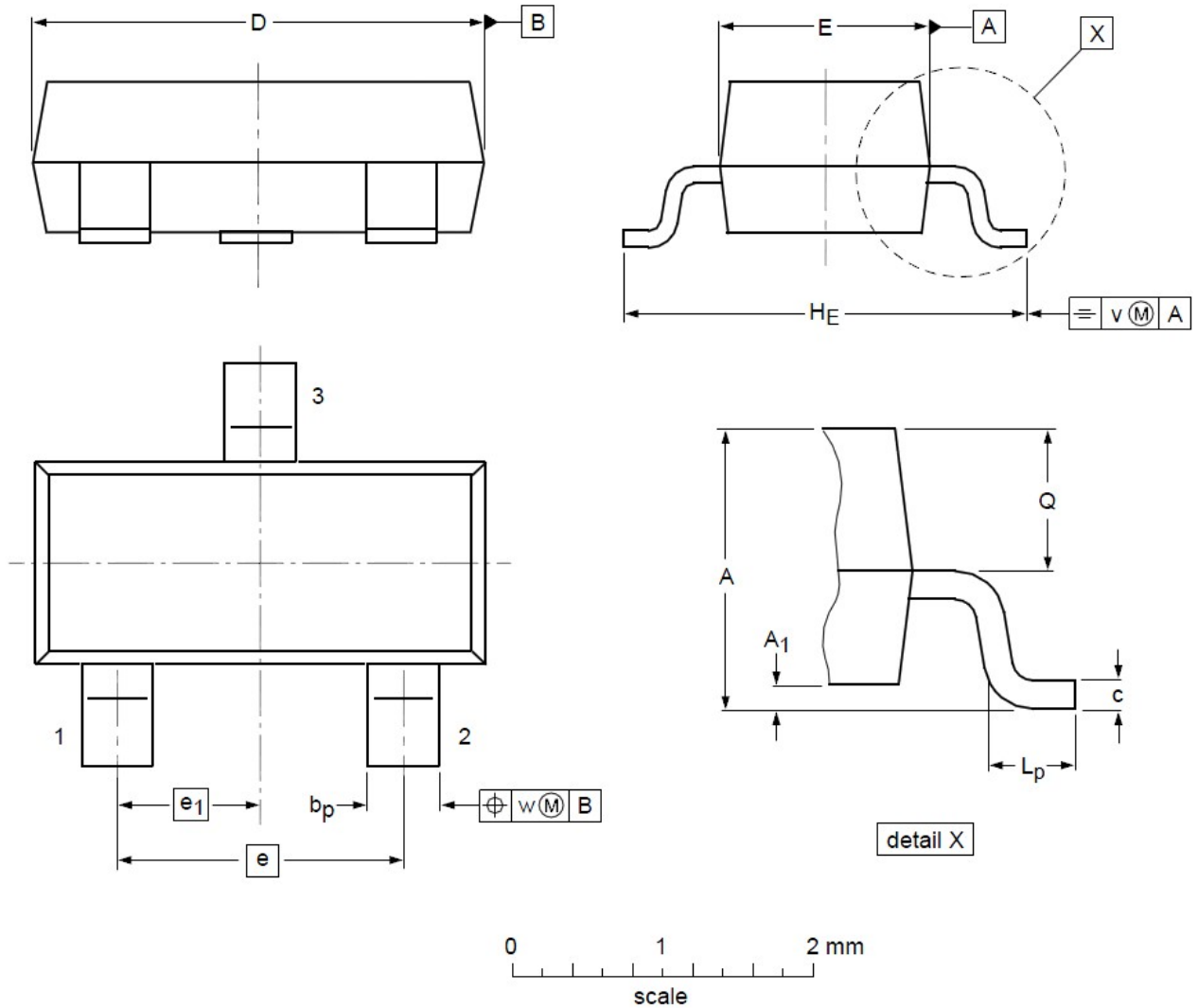


**Fig9.** Normalized Maximum Transient Thermal Impedance



**Fig10.** Switching Time Test Circuit and waveforms

**SOT23 Mechanical Data**



**DIMENSIONS** ( unit : mm )

Symbol	Min	Typ	Max	Symbol	Min	Typ	Max
<b>A</b>	0.90	1.01	1.15	<b>A<sub>1</sub></b>	0.01	0.05	0.10
<b>b<sub>p</sub></b>	0.30	0.42	0.50	<b>c</b>	0.08	0.13	0.15
<b>D</b>	2.80	2.92	3.00	<b>E</b>	1.20	1.33	1.40
<b>e</b>	--	1.90	--	<b>e<sub>1</sub></b>	--	0.95	--
<b>H<sub>E</sub></b>	2.25	2.40	2.55	<b>L<sub>p</sub></b>	0.30	0.42	0.50
<b>Q</b>	0.45	0.49	0.55	<b>v</b>	--	0.20	--
<b>w</b>	--	0.10	--				